

# ROTATOR | ROTATOR - AV 14S

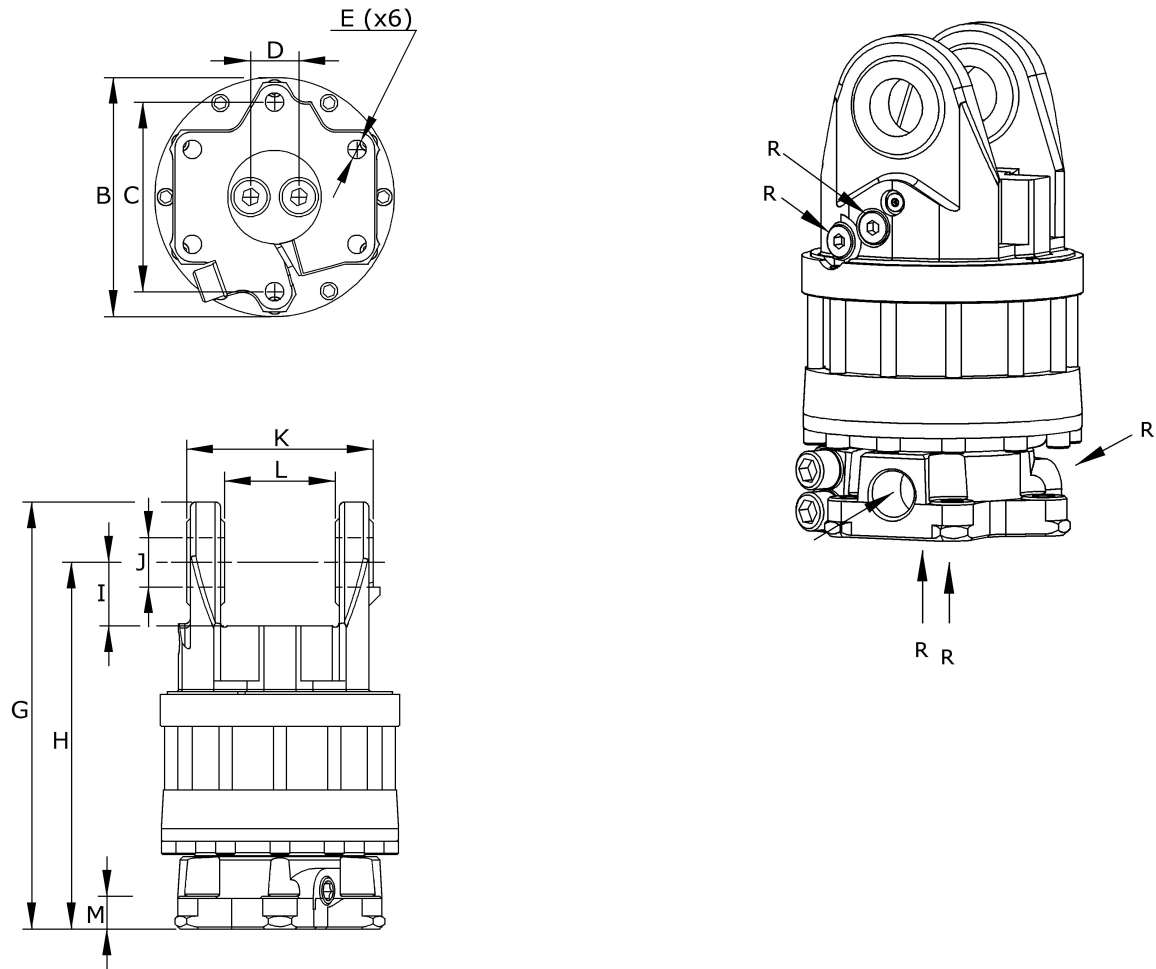

## Technical data

Part no	5214 296
Dimensional drawing	2000 693
Hydraulic circuit	2100 007
Rotation	unlimited
Weight	55,5 kg
Max axial load, static	100 kN
Max axial load dynamic	50 kN
Torque at 25 MPa	3300 Nm

## Function

Function	Max working pressure	Rec oilflow
R = Rotation ⇐ ⇒	25 MPa	35 l/min

## Connections<sup>1</sup>

Upper	G 1/2
Lower	G 1/2

<sup>1</sup> We supply adapter sets for alternative connections

\* For more technical information about installation and hydraulic connections, we refer to dimensional drawing and hydraulic circuit as specified above. These documents can be ordered at [rotator@indexator.com](mailto:rotator@indexator.com)

## Measure specification

	mm
B	Ø218
C	Ø173
D	38,5
E	Ø17
G	388
H	333
I	58
J	Ø45*
K	170
L	101*
M	30